

The production of hydrogen through the use of a 77 wt% Pd 23 wt% Ag membrane water gas shift Reactor

Liberty N. Baloyi, Brian C. North, Henrietta W. Langmi, Bernard J. Bladergroen and Tunde V. Ojumu

Abstract

Hydrogen as an energy carrier has the potential to decarbonize the energy sector. This work presents the application of a palladium-silver (PdeAg) membrane-based reactor. The membrane reactor which is made from PdeAg film supported by porous stainless steel (PSS) is evaluated for the production of hydrogen and the potential replacement of the current two stage Water-Gas Shift (WGS) reaction by a single stage reaction. The permeability of a 20 mm PdeAg membrane reactor was examined at 320 °C, 380 °C and 430 °C. The effect of continuous hydrogen exposure on the PdeAg membrane at high temperature and low temperature was examined to investigate the thermal stability and durability of the membrane. During continuous operation to determine thermal stability, the membrane reactor exhibited stable hydrogen permeation at 320 °C for 120 h and unstable hydrogen permeation at 430 °C was observed. For the WGS reaction, the reactor was loaded with Ferrochrome catalyst. The membrane showed the ability to produce high purity hydrogen, with a CO conversion and an H₂ recovery of 84% and 88%, respectively. The membrane suffered from hydrogen embrittlement due to desorption and adsorption of hydrogen on the membrane surface. SEM analysis revealed cracks that occurred on the surface of the membrane after hydrogen exposure. XRD analysis revealed lattice expansion after hydrogen loading which suggests the occurrence of phase change from a-phase to the more brittle b phase.

1. Introduction

In South Africa, the energy supply is dominated by coal, which is 65.7% of the primary energy supply. This is followed by crude oil with 21.6%, renewable and wastes with 7.6% and gas with 2.8% (Maleka et al., 2010). The use of these carbon intense materials as a primary source of energy has a significant impact on our environment and may be the main reason for global warming. Hydrogen is considered to be a promising alternative clean energy carrier; it has the potential to revolutionize the energy sector from household applications, to transportation and to industrial processes (Mendes et al., 2010). The Department of Science and Technology (DST) of South Africa developed the National Hydrogen and Fuel Cells Technologies, Research, Development and Innovation Strategy. The national strategy was branded Hydrogen South Africa (HySA). The overall goal of HySA is to develop and guide innovation along the value chain of hydrogen and fuel cell technologies in South Africa.

HySA has been established consisting of three Centres of Competence, namely HySA Infrastructure, HySA Catalysis and HySA Systems. HySA Infrastructure focusses on hydrogen production, storage and distribution. A key aim is to promote the incorporation of Platinum Group Metals (PGMs) as part of the national mineral beneficiation strategy. At present, 96% of hydrogen is produced directly from fossil fuels and only about 4% is produced by the use of renewable resources that are carbon free (Abdollahi et al., 2012). The production of hydrogen is expected to increase in the future as the world moves toward the greater use of hydrogen as an energy carrier. The main challenge for the upcoming generation is to increase the production of hydrogen through processes which are environmentally friendly and economically and technically feasible. Furthermore, the demand for high purity hydrogen has also increased due to fuel cells applications. Fuel cell devices require high purity hydrogen (less than 50 ppm of CO) as a fuel, to prevent deactivation of the anode since it is made of platinum which is CO intolerant (Okazaki et al., 2011). Palladium (Pd)-based membrane reactors have long been identified as a promising alternative solution for producing high purity hydrogen in industrial processes (Abdollahi et al., 2012; Okazaki et al., 2011; Isaeva et al., 2011; Augustine et al., 2012). A Pd-based membrane reactor offers the advantage of combining the reaction and separation steps into a single unit (Peters et al., 2009). The Water-Gas Shift (WGS) reaction has been identified as one of the processes which both hydrogen yield and purity can be improved by using a membrane reactor. The WGS reaction is the reaction that converts CO and H₂O into CO₂ and H₂. This reaction is represented by Equation (1).

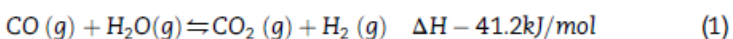

The use of a membrane reactor for hydrogen production offers advantages when compared to the traditional packed bed reactors used for the WGS reaction. The use of Pd membrane reactors for replacing the current two-stage process of the WGS reaction potentially eliminates energy-intensive downstream hydrogen purification and recovery process such as pressure swing adsorption or cryogenic processes (Cooney et al., 2014). It has been highlighted that the use of a Pd membrane reactor for WGS reaction suppresses the equilibrium limitations encountered by current packed bed reactors (Abdollahi et al., 2012; Augustine et al., 2011). The WGS reaction is exothermic and the reaction is currently carried out at high (320-360 °C) and low (190-250 °C) temperatures (Nakamura et al., 1990). The first stage is for achieving faster reaction kinetics and the second stage is for attaining a higher yield through conversion of the small amount of CO not converted in the first stage due to the equilibrium limitation. In contrast, a Pd-membrane reactor combines the two into a single unit. A Pd membrane has the ability to achieve higher conversion because during the reaction a selective membrane continuously removes products. The permeation of hydrogen through the membrane follows the solution diffusion mechanism which involves a series of steps; (i) Adsorption of hydrogen on the membrane surface on the feed side, (ii) dissociation of hydrogen, (iii) diffusion of hydrogen atoms through the metal lattice by two transition phenomena (surface-to-bulk and bulk-to-surface) and (IV) recombination of hydrogen atoms on the permeate side (Caravella et al., 2010). Each of these steps can be the

potential rate limiting step for hydrogen transport through the PdAg membrane. There are certain drawbacks concerning the adoption of membrane reactors for replacement of conventional two stage WGS reactors. Fundamental science still needs to be addressed for membrane reactors to be adopted for industrial applications. Pure Pd-based membrane reactors suffer from hydrogen embrittlement when exposed to hydrogen at temperatures below 293 °C. When a Pd based membrane is exposed to hydrogen palladium hydride (Pd-H_n) forms on a non-stoichiometric basis (Okazaki et al., 2006). This reaction is reversible. The hydride can exist in two phases depending on the stoichiometric ratio of the hydride. The first phase is a phase which exists below PdH_{0.02} and the second is the β phase which solely exists above PdH_{0.58}. At PdH_{0.02} < 0.058 both phases co-exist. The β phase has been reported to be brittle, resulting in the so called “Hydrogen embrittlement” when phase transition occurs (Okazaki et al., 2011). To suppress the effect of hydrogen embrittlement, Pd is mostly alloyed with Cu, Au and Ag. Thoen et al. (2006) reported that alloying Pd with Ag or Cu can reduce the cost of the membrane and improves the Pd embrittlement threshold temperature. In addition, PdAg based membranes have higher permeability in comparison to pure Pd-based membranes. Another challenge associated with palladium membrane reactors is intermetallic diffusion. Intermetallic diffusion is defined as the migration of elements from the porous metal support material (mostly Fe, Cr, and Ni) into the Pd layer (Edlund and McCarthy, 1995). It has been highlighted that intermetallic diffusion is one of the problems which is encountered by supported membranes; it reduces the permeability, selectivity and life span of the membrane (Edlund and McCarthy, 1995; Ma et al., 2004; Chotirach et al., 2012). However, it can be mitigated by forming a metal oxide layer between the support and the film. Chromium oxide has been reported to suppress intermetallic diffusion which improved the mechanical and thermal stability of the membrane. Edlund and McCarthy (1995) investigated the relationship between intermetallic diffusion and the hydrogen flux decline within a composite palladium membrane. It was highlighted from the study that there was a correlation between the flux decline and the degree of intermetallic diffusion. Cooney et al. (2014) examined the permeation stability of hydrogen through a Palladium Vanadium composite membrane at 500 °C for 120 h. The permeation stability of hydrogen was reported to have varied significantly. The membrane failed within the first 20 h due to poor mechanical integrity to a combination of PdV inter-diffusion and high susceptibility to oxidation. Okazaki et al. (2011) investigated the thermal stability of Pd₈₀Ag₂₀ supported by porous α-Al₂O₃ at temperatures between 380 and 830 °C. At temperatures above 600 °C the permeation rate of hydrogen declined due to intermetallic diffusion between Pd and the support. Stable permeation was observed for 100 h at 550 °C. A study by Chotirach et al (Chotirach et al., 2012) confirms the findings of Okazaki et al. (2011) that intermetallic diffusion starts occurring at the Tamman temperature of the support material. (Tamman Temperature is generally half the melting temperature and is considered the point at which sintering begins in ceramics materials). Mardilovich et al. (1998) tested a palladium membrane based reactor for 1100 h at 350 °C. The membrane suffered from recrystallization texture (cluster of grains due to nucleation) and aggregation of Pd grains due to long-term hydrogen exposure. The membrane could not withstand high temperatures of 550 °C due to intermetallic diffusion. Augustine et al. (2012) studied the durability of Pd membranes supported by oxidized porous stainless steel with an aluminium

oxide inter metallic diffusion barrier for mixed gas under WGS reaction conditions for 1000 h. The membrane suffered from coke formation after 65 h of operation. The membrane also suffered from leaks, some of which were due to welding. Furthermore, work by [Augustine et al. \(2011\)](#) showed a decline in the permeation of hydrogen due to coke formation. The selectivity also declined to an unknown leak growth mechanism. [Abdollahi et al. \(2012\)](#) utilized a Pd-based membrane to produce ultrapure hydrogen. The membrane showed complete conversion of carbon monoxide and almost 100% hydrogen recovery. In this work a PdeAg membrane-based reactor consisting of PdeAg film supported by porous stainless steel (PSS) is employed for the production of hydrogen from the WGS reaction.

2. Experimental procedure

2.1. Membrane preparation and materials

An alloy of PdeAg film was purchased from a Japanese company Tanaka Kikinzoku group. According to the manufacturer's specifications, the alloy is a mixture of 77wt%Pd and 23wt%Ag with a thickness of 20 μm . The membrane reactor was designed by the South African Institute of Advanced Materials Chemistry at the University of the Western Cape (UWC). It consists of two stainless steel plates, shown in [Fig. 1](#). Plate A is punched with a single outlet for permeate products. Plate B has two holes punched within the plate at the edge of the catalyst channel volume, one for the feed supply and the other for the reject stream. Plate B also has a catalyst channel with a volume of 2.88 cm^3 (8 $\text{cm} \times 0.7 \text{ cm} \times 0.7 \text{ cm}$) as shown in [Fig. 1](#). Plate A was fitted with a porous stainless steel (PSS) support supplied by Mott Company which is a South African company based in Cape Town: The PSS had an active surface area of 5.6 cm^2 (8 $\text{cm} \times 0.7 \text{ cm}$). The PSS support was glass sealed into plate A at 600 $^\circ\text{C}$ in air to offer a continuous mechanical pre oxidized support for the free standing PdeAg film. A graphite gasket was employed as a high temperature seal. The components shown in [Fig. 1](#) were assembled to form a PdeAg membrane reactor. Whilst the feed side of the membrane was exposed to 10 bar N_2 , the membrane reactor was submerged into a vessel filled with water. The absence of rising bubbles or any permeate confirmed a leak free system. After the leak test, the membrane reactor was encased within a furnace as shown in [Fig. 2](#).

2.1.1. Experimental set-up

The experimental setup was designed and constructed at the University of the Western Cape (UWC) specifically for the measurement of hydrogen permeance (flux rate) through composite membrane reactors. The system was designed to operate at pressures up to 10 bar and incorporates a furnace that can heat up a gas preheater and the membrane reactor to a maximum temperature of 600 $^\circ\text{C}$. A schematic overview of the setup is given in [Fig. 3](#). The set-up consists of a feed section, membrane reactor section, cooling section and a gas analysis section with micro Varian Gas Chromatograph (GC). The feed section consists of different gas lines (CO , H_2 , CO_2 and N_2) which supply the gases into the system at a pressure of 10 bar from cylinders. A pressure regulator R (0e20 bar) and back pressure regulator (BPR) (0e7 bar) from Swagelok are used to control the pressure of the gases. The BPR is used to regulate the reject gas pressure; it also acts as a relief valve if the system pressure builds over the operating specification.

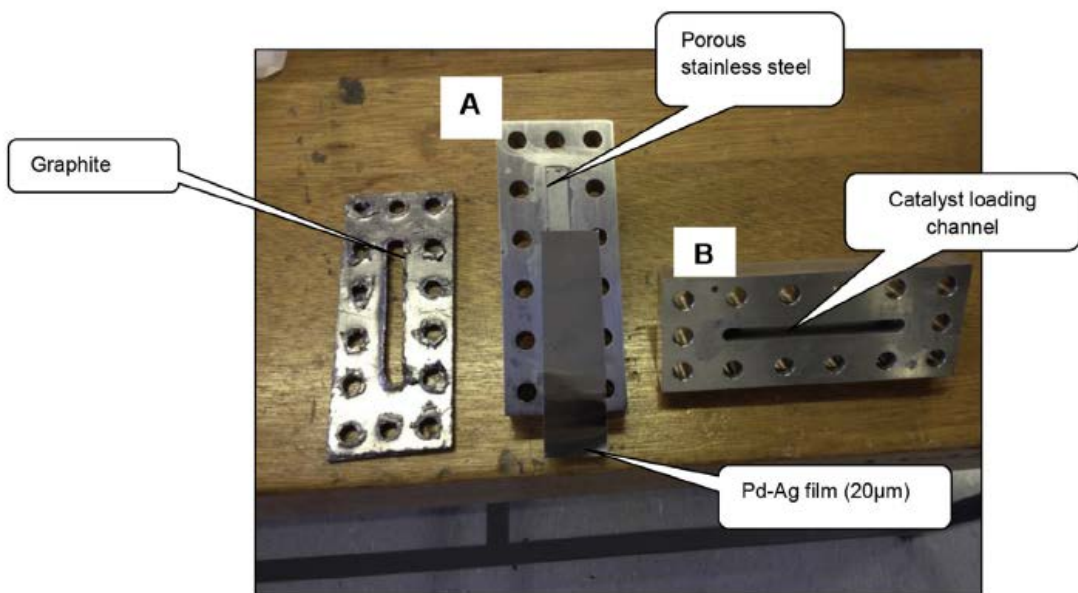

Fig. 1 – Components of membrane reactor.

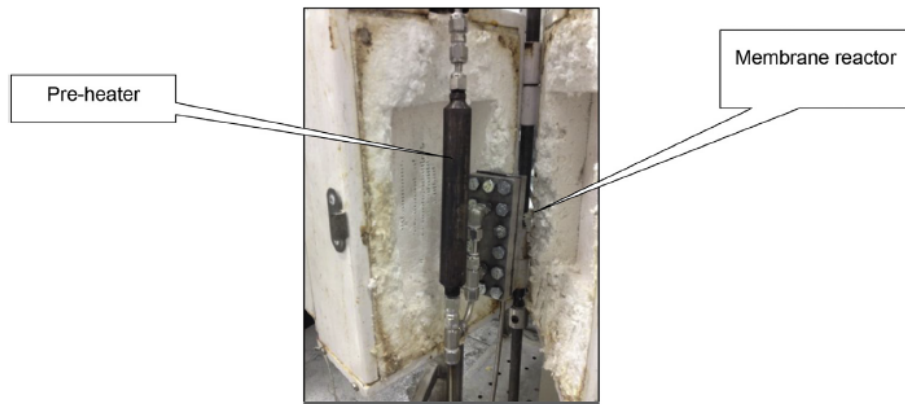

Fig. 2 – Membrane reactor encased within a furnace.

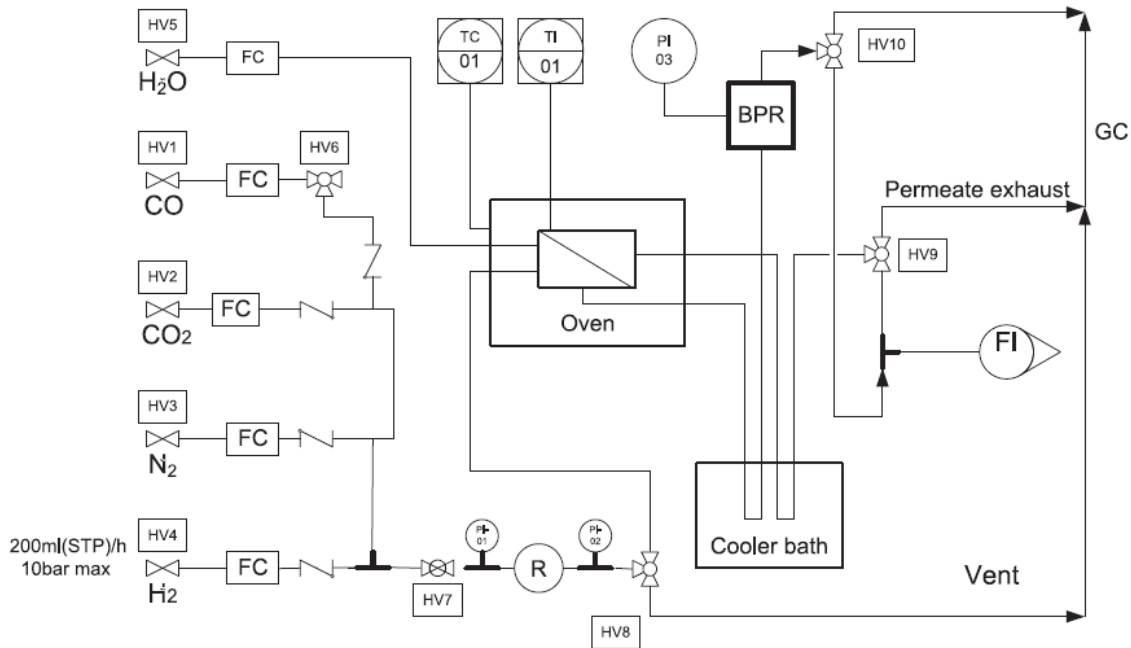

Fig. 3 – Process flow diagram for water gas shift reaction.

The membrane section consists of a membrane reactor, as shown in Fig. 2, encapsulated inside a furnace. The gas pre-heater and the membrane reactor (not shown in the Fig. 3) are both equipped with a K type thermocouple to measure the entering gas temperature. The cooling system consists of two coiled tubes submerged within an actively cooled water bath. Within the cooling bath, there is a vessel connected to the permeate stream to collect the steam before the GC for compositional analysis. Downstream the cooling system a soap flow bubble meter and a GC were installed to measure the flow rate and composition of both the permeate and the non-permeate streams. An online dual channel CP-4900 Micro GC with both N₂ and H₂ as carrier gas was used to determine the gas composition of reject and permeate streams. Firstly, the GC was calibrated with pure gases (N₂, H₂, CO and CO₂) in order to determine the different retention time and relative peak areas for each injected gas. The injection temperature was set to 100 °C to prevent condensation of water. The column

temperature and pressure was set at 100 °C and 50 kPa respectively. The injection volume ranged from 1 to 10 mL.

2.2. Membrane characterisation

A scanning electron microscope (SEM; JEOL-JSM 7500F) was used to investigate surface changes on the membrane film before and after exposure to hydrogen with optimised conditions of 3 kV of energy, a tilt angle of 0° and a port size of 9. XRay Diffraction (XDR) was performed using a PAN analytical X'pert pro diffractometer with CuK α radiation, with a wavelength of 1.54 Å as a radiation source operating at 45 kV and 40 mA. The XRD patterns were observed between 0 and 90°.

3. Results and discussion

3.1. Hydrogen permeability

Gas permeability is the volume of gas passing through a material of unit thickness per unit area and unit time under unit partial pressure difference between two sides of material (Morreale et al., 2003). The permeability of hydrogen was investigated at different temperatures as indicated in Fig. 4. The permeability of hydrogen was estimated based on Sievert's equation for ideal gas diffusion, represented by Equation (2). In Equation (2), J_{H_2} denotes the hydrogen flux (mol m⁻² s⁻¹), P_{H_2} hydrogen permeability (mol s⁻¹ m⁻¹ Pa⁻¹), n the exponential factor, (P_{feed}) pressure of the feed stream and ($P_{permeate}$) the pressure on the permeate side. Equation (2) adopted from (Caravella et al., 2010).

$$J_{H_2} = \pi_{H_2} \left(P_{H_2}^{n_{feed}} - P_{H_2}^{n_{permeate}} \right) \quad (2)$$

From Fig. 4 an increase in temperature results in a positive effect on the permeation rate of hydrogen through the membrane. The permeability of hydrogen increases as temperature is increased because the average kinetic energy of molecules is increased, which causes the hydrogen atoms to diffuse through the membrane faster (Caravella et al., 2010). Therefore, at higher temperatures, the diffusion rate of hydrogen is favoured. The hydrogen permeability increases linearly with an increase in pressure difference regardless of the operating temperature, because the pressure difference ($P_{feed} - P_{permeate}$) is the driving force for the diffusion process, Similar results were reported by other researchers (Morreale et al., 2003; Hara et al., 2012; Okazaki et al., 2006; Uemiya et al., 1991). The permeation of hydrogen through the membrane follows the solution diffusion mechanism which involves a series of steps as explained in the introduction; each of these steps can be the potential rate limiting step for hydrogen transport through the PdAg membrane. The rate limiting step for hydrogen permeation is estimated based on the n value from Sieverts equation. The exponent “ n ” from Equation (1) is usually evaluated by means of a nonlinear regression. The “ n ” value was found to be 0.523 at 320 °C, 0.65 at 380 °C and 0.62 at 430 °C. Caravella et al. (2010) analysed the physical meaning of the “ n ” value, if $n \leq 0.5$, bulk diffusion of hydrogen is the rate limiting step, “ $0.5 < n < 1$ ” the surface contamination is the rate limiting step and $n < 0.5$ the thickness of the membrane plays a role. This suggests that at 320 °C the bulk diffusion of hydrogen is the rate limiting step for hydrogen permeability. At 380 and

430 °C surface contamination can possibly be the rate limiting step for hydrogen permeating through the metal membrane.

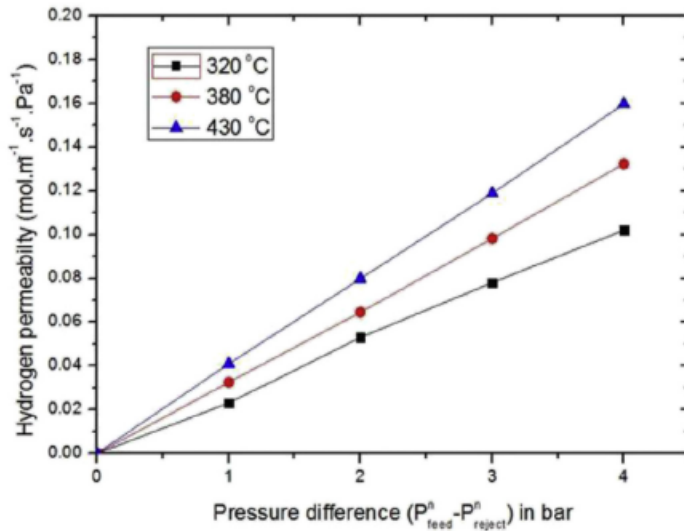

Fig. 4 – Permeability of hydrogen at different temperatures.

3.2. Thermal stability of the membrane

Thermal stability of a membrane within the context of this work refers to the extent at which the membrane rejects N₂ over time at temperatures up to 430 °C. Fig. 5 represents the thermal stability of the PdAg membrane at 320 °C and 430 °C under continuous exposure to hydrogen and nitrogen. Nitrogen was used for checking leaks through the membrane, since it is an inert gas which does not permeate through a Pd membrane. From Fig. 5 a steady permeation of hydrogen was observed for 160 h at 320 °C. The membrane started allowing the non-permeate gas (nitrogen) to permeate through it at time after 170 h, which indicated that the membrane developed some defects. The thermal stability was also studied at 430 °C, at which temperature a steady state permeation rate of hydrogen was observed until 150 h. Cooney et al. (2014) investigated the thermal stability of palladium composites (Pd/V and Pd/Nb) at 500 °C. The Pd/V composite failed within the first 20 h due to the Pd/V inter-diffusion. The Pd/Nb failed after 48 h due to poor mechanical strength and recrystallization texture. For the work described in this paper, the PdAg has a face centred cubic (FCC) structure, which is more stable compared to the Pd/V which has a body centred cubic (BCC) structure. Cooney et al. (2014) also outlined that Pd/Nb suffers from hydrogen embrittlement quickly at temperatures below 350 °C which causes the membrane to break. Okazaki et al. (2011) investigated the thermal stability of a thin PdAg membrane at temperatures ranging from 300 °C to 700 °C. The membrane showed stable hydrogen permeation below 550 °C, however, above 600 °C the permeation declined due to intermetallic diffusion. Several studies (Abdollahi et al., 2012; Cooney et al., 2014; Tosti et al., 2006; Criscuoli et al., 2000; Chein et al., 2013) reported the mechanical failure of the membranes being related to a temperature gradient and high pressure stress since the

membranes were mostly thin. However, in this work, the PdAg membrane suffered from phase change which resulted in lattice expansion as explained later.

3.3. Durability of the membrane

The ability of a membrane to withstand a variety of process conditions such as high pressures, high temperatures and aggressive compounds, while maintaining its performance over a long period of time without structural changes, reflects its durability (Liguori et al., 2014).

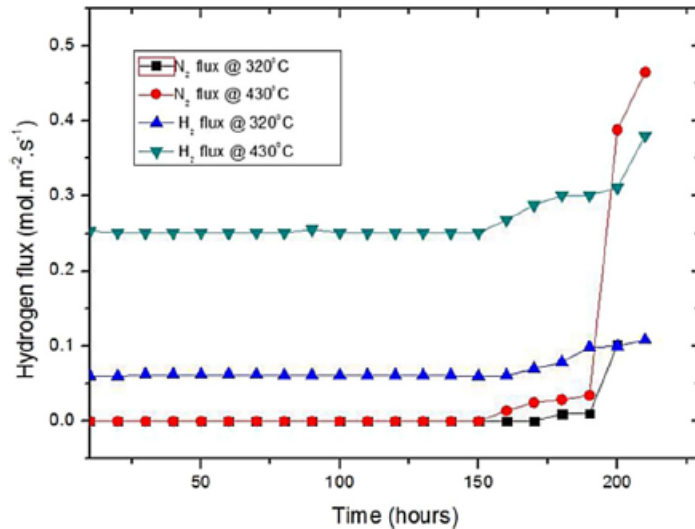

Fig. 5 – Thermal stability of Pd–Ag membrane under continuous exposure of hydrogen and nitrogen.

Fig. 6 represents hydrogen permeation under different process conditions. This was done in order to investigate the durability of the PdAg membrane. This work focused on long-term hydrogen exposure at different temperatures and pressures. Fig. 6 represents the membrane durability under different process conditions over 180 h. Non-permeate gas (nitrogen) started permeating through the membrane after 150 h, which was an indication that the membrane had become damaged as shown by the SEM images in Fig. 10. A study by Isaeva et al. (2011) highlighted that the hydrogen stored in metals causes microstructural changes in the host metallic matrix which can lead to undesirable changes in physical and mechanical properties of the material, such as hydrogen embrittlement. Numerous studies (Abdollahi et al., 2012; Cooney et al., 2014; Tosti et al., 2006; Criscuoli et al., 2000; Chein et al., 2013) reported the mechanical failure of the membrane due to heat treatment and high pressure stress. Since the membranes were mostly thin, the mechanical failure occurred between the support material (substrate) and the deposited Pd-layer. In the current work, the membrane failed due to continuous loading of hydrogen on the membrane. The membrane was under stress that this may have caused defects during long term operation of the membrane. Evidence of this is presented by XRD data that shows that lattice expansion (from 3.804 to 3.880 Å) occurred within the crystals, which resulted in the membrane cracking and forming spaces which allowed nitrogen to permeate through the membrane.

3.4. Water-gas shift (WGS) reaction

The PdeAg membrane reactor loaded with ferrochrome catalyst was used to produce hydrogen via the WGS reaction. The PdeAg membrane produced high purity hydrogen. The performance of the membrane reactor was evaluated based on the recovery of hydrogen and the conversion of CO. The following equations were used to evaluate the PdeAg membrane reactor performance.

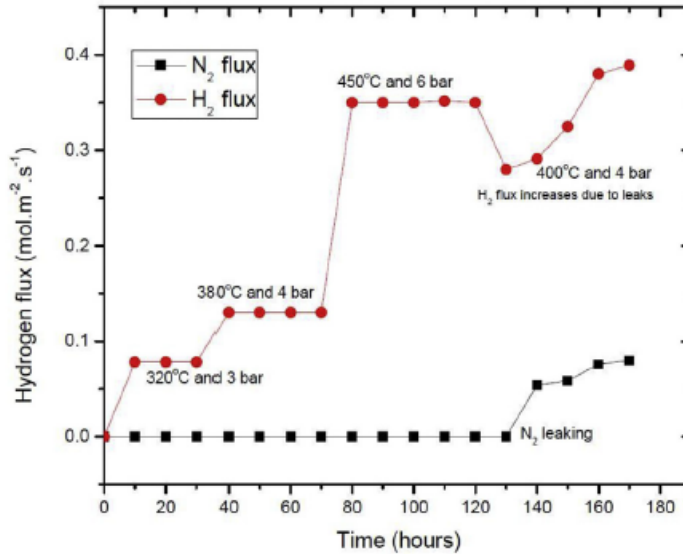

Fig. 6 – Hydrogen flux at different process conditions.

$$X_{CO} = \frac{F_{CO_{inlet}} - F_{CO_{outlet}}}{F_{CO_{inlet}}} \times 100\% \quad (3)$$

Where X_{CO} represents the conversion of the CO in %, F_{CO} represents the flow rate (inlet and outlet).

$$H_{2recovery} = \frac{H_{2perm}}{H_{2perm} + H_{2rejec}} \times 100\% \quad (4)$$

Where $H_{2recovery}$ represents hydrogen recovery and H_{2perm} represents hydrogen in moles at the permeate side of the membrane. The calculation of the conversion and hydrogen recovery through the membrane was based on Equations (3) and (4) respectively. Different process parameters were investigated to evaluate the performance of the PdeAg membrane WGS reactor.

3.4.1. Effect of temperature on WGS reaction

A change in temperature has two general opposite effects when membrane reactors are used for hydrogen production via the WGS reaction. Firstly, an increase in temperature leads to a positive effect on the permeability of hydrogen through the membrane, since the enthalpy of

adsorption and diffusion is greater at higher temperatures as illustrated in Fig. 4 for hydrogen permeability at different temperatures. On the other hand, the WGS reaction is exothermic; therefore the forward reaction is favoured at low temperatures causing the equilibrium to shift away from the hydrogen production side with increasing temperature. Fig. 7 represents the effect of temperature on WGS reaction performed at 4 bar and a steam: CO ratio of The performance of the PdeAg membrane reactor was evaluated based on CO conversion and hydrogen recovery. From Fig. 7 the highest achieved conversion of CO was 84% at 320 °C and 4 bar. At the same conditions for the highest conversion, the lowest hydrogen recovery of 74% was achieved. An inverse relationship exists between hydrogen recovery and conversion of CO. As the temperature increased, the conversion of CO declined. The inverse relationship can be explained by Le Chatelier's principle for a reaction at equilibrium. An increase in temperature favours an endothermic reaction. In the case of the WGS reaction, the reverse reaction has been favoured since the forward reaction is exothermic. Therefore, with an increase in temperature the reverse reaction is favoured and the conversion is still higher than for traditional packed bed reactors normally used for WGS reaction due to the constant selective removal of hydrogen from the reaction zone through the membrane.

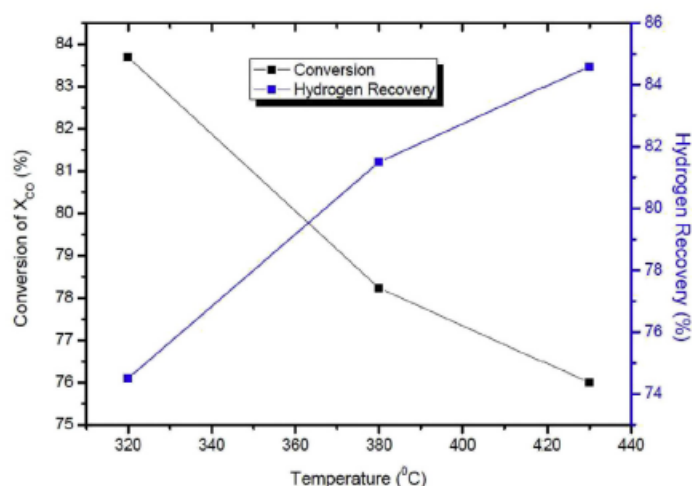

Fig. 7 – Effect of temperature on CO conversion and hydrogen recovery.

For membrane reactors, operation at higher temperatures favours reaction kinetics and the permeability of hydrogen. The highest hydrogen recovery was 82%, which was attained at 430 °C, albeit at are relatively low conversion rate.

3.4.2. Effect of steam ratio on WGS reaction

The quantity of hydrogen produced depends on the amount of steam supplied during the reaction. Fig. 8 represents the effect of steam ratio (molar basis) on hydrogen recovery at 320 °C and 430 °C. The experiments were performed at a reject pressure of 2 bar. The hydrogen recovery increases as the steam ratio increases, since there is more hydrogen to be generated

from the steam and due to the Le Chatelier's principle shift effect of change in concentration. However, it is reported in literature that higher steam content for a membrane reactor affects the permeation rate due to competitive adsorption (Unemoto et al., 2007). The current industrial WGS process is operated with an excess of steam in order to favour the equilibrium shift to the side of products (Diogo Manuel Pereira Mendes, 2010). However, the presence of excess steam in membrane reactors while conducting WGS reaction has been reported to affect the hydrogen permeation rate negatively (Hwang et al., 2013). In this work, the competitive adsorption was suppressed by temperature, as can be seen from Fig. 8. At a higher temperature (430 °C), but with equal steam ratio, the permeation of hydrogen was greater than at 320 °C. According to Tosti (2010) an excess of steam has a greater negative effect on the permeation rate of hydrogen in comparison to CO content. If the steam is adsorbed on the surface of the palladium membrane, the adsorbed water dissociates and recombines according to Equations (5) and (6) to form H₂O which hinders the permeation site for H_{ads} to diffuse through the membrane.

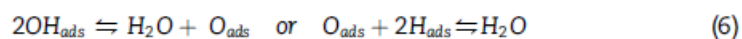
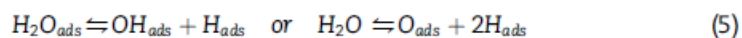

Hou and Hughes (2002) investigated the effect of higher steam ratio on membrane reactors. They indicated that a higher steam ratio leads to higher conversion. However, excess steam ratio causes hydrogen dilution on the membrane surface and a decrease in hydrogen recovery.

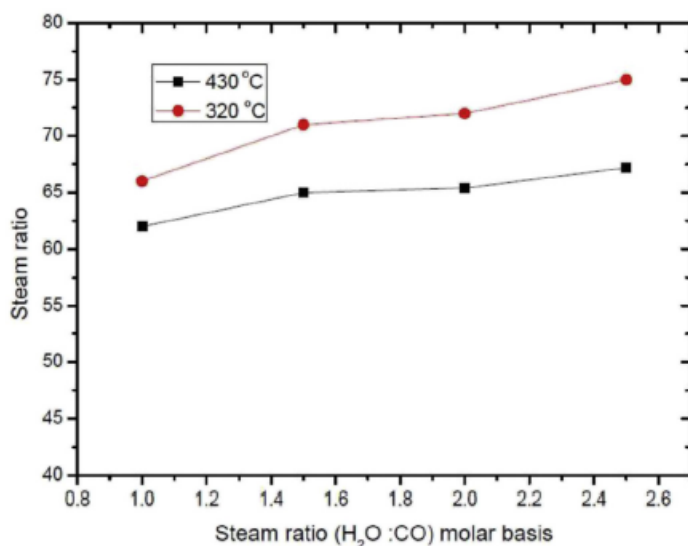

Fig. 8 – Effect of steam on hydrogen recovery at fixed CO amount.

In the work reported here, the hydrogen recovery did not decrease relative to an increase in the steam ratio for the investigated steam: CO ratio limits.

3.4.3. Stability of the membrane under WGS reaction conditions

The objectives of this work were to produce high purity hydrogen through the use of a PdAg membrane supported by PSS material. A long-term (100 h) study for producing hydrogen at fixed process conditions was conducted, with the objective of understanding the gradual change of membrane performance. The membrane performance was evaluated based on conversion of CO and recovery of H₂. Fig. 9 represents the conversion of CO and hydrogen recovery over time at 380 °C and 3 bar at a steam: CO ratio of 2.5 both conversion of CO and hydrogen recovery deteriorated over time. The conversion of CO remained stable at approximately 83% for the first 40 h. However, after 40 h the conversion showed an increasing declining, and fell to 79% at 100 h. Furthermore, the hydrogen recovery also declined by 5% from initial permeance levels. It was reported by Hou (Hou and Hughes, 2002) that continuous exposure of gases (CO and H₂S) to Pd membrane surface can cause membrane deactivation. Deactivation occurs when coke is formed on the membrane surface which leads to a decrease in the permeance of H₂. Coke deposits on the membrane film were indeed confirmed by SEM, see Fig. 10. Coke deposits block the active site for hydrogen to dissociate and diffuse through the membrane. The produced hydrogen was 99.99% pure, as observed from GC results. Augustine et al. (2011) investigated the performance of a WGS membrane reactor under industrial process conditions over time. The tested membrane showed stable permeation of hydrogen for the first few days, but as time passed the selectivity of the membrane declined due to leaks which occurred within the membrane. The purity of hydrogen dropped due to the presence of non-permeable species (CO, N₂ and CO₂). In a prior study by Basile et al. (1996) a PdAg membrane reactor was operated for 8 days and showed initially stable results and a conversion of 99.89% at 3 bar and 350 °C with the use of N₂ as sweep gas. However, after 3 days, the membrane failed due to mechanical problems, and at day 6, the membrane started leaking due to the leak growth mechanism. The leak growth mechanisms are not fully detailed. There is limited literature covering long-term tests for hydrogen production through the use of a Pd membrane.

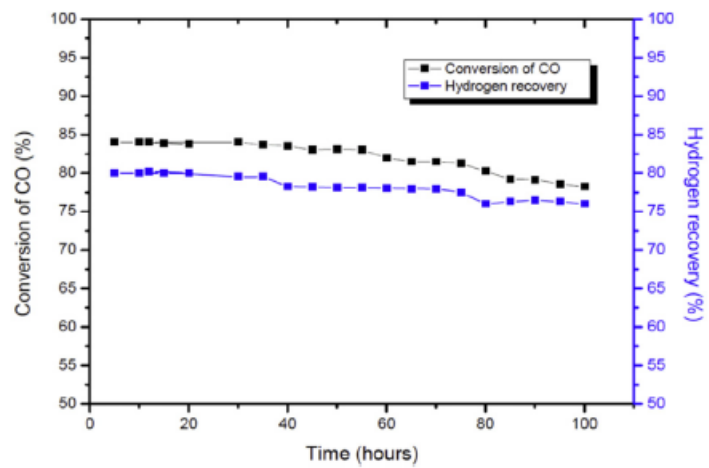

Fig. 9 – The long-term performance of Pd–Ag membrane to produce hydrogen.

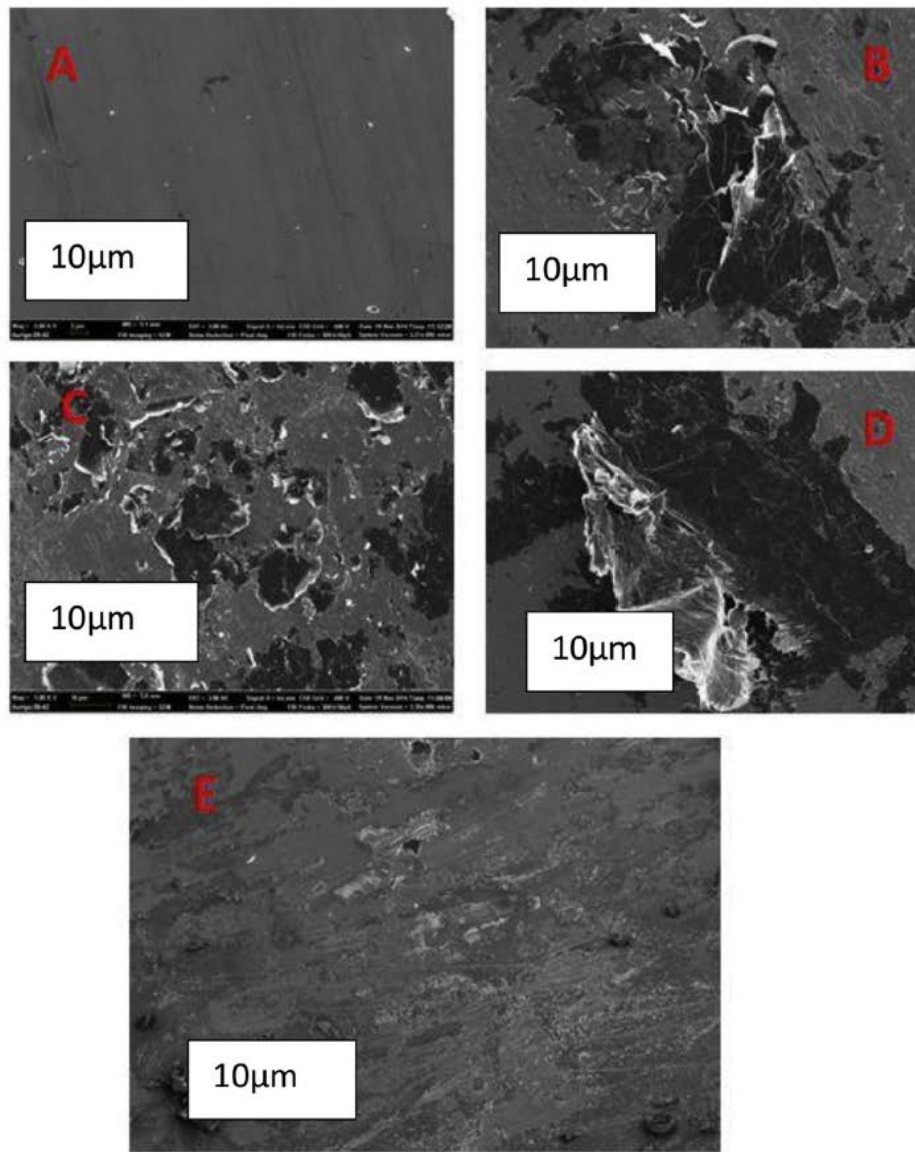

Fig. 10 – SEM images: (A) Pure Pd–Ag membrane, (B) Pd–Ag membrane used for durability testing, (C) feed side WGS reaction long-term H₂ exposure at 320 °C, (D) thermal stability feed section at 450 °C, and (E) permeate side for WGS reaction.

Lin and Rei (Lin and Rei, 2001) tested the permeability of hydrogen under methanol reforming conditions at 350 °C for 900 h using a 20 mm Pd-based membrane. Their study revealed stable permeation and selectivity for the entire period.

3.5. Microstructure and phase analysis

3.5.1. SEM analysis

The material was examined under a Scanning Electron Microscope (SEM) to investigate surface changes on the PdAg film membranes exposed to hydrogen. Fig. 10 represents SEM images for the PdAg film under different process variables. From Fig. 10(A), the PdAg film showed a uniform surface without cracks or pinholes before hydrogen exposure. Image (B) represents the feed side of PdAg film under hydrogen exposure at high and low temperatures. There is a significant difference between image (A) and image (B). Image B

shows major cracks formed during the diffusion of hydrogen atoms at different process conditions. During the durability test, the colour changed (from silver to silver grey) due to thermal treatment. Fig. 10(C) deposits are observed on the film which can be coke formed during the WGS reaction, which caused the decline in hydrogen recovery. Fig. 10(D) shows significant surface structural changes which exist on the PdeAg film before and after hydrogen exposure. Major cracks on the surface were observed after hydrogen exposure. These cracks are not formed because of thermal stress or mechanical failure of the membrane. These cracks are due to crystalline phase change from a phase to bphase which is brittle. Suleiman et al. (2003) reported that a continuous loading of hydrogen causes lattice dilation, which results in cracking of the membrane. The absorption and desorption of hydrogen atoms on the FCC has been reported to form PnHn depending on the concentration of hydrogen and exposure temperature. The formation of Pd-hydride has the potential of causing cracks in membrane films depending on the phase of the hydride.

Table 1 – Lattice parameters for Pd–Ag membrane film.

Process conditions	a (Å)	d(Å)	Reference
Pd–Ag (pure)	3.804	5.083	Current work
Pd–Ag (thermal stability)	3.984	5.880	Current work
Pd–Ag (membrane durability)	3.989	5.841	Current work
Pd–Ag(WGS reaction)	3.994	5.8745	Current work
Pd (pure)	3.895	5.804	(Ungár, 2004)
Pd (exposed to hydrogen)	3.925	5.550	(Ungár, 2004)

XRD data refinement revealed lattice expansion as presented in Table 1, which indicates the negative effect of phase transition. It can be observed from the SEM image (E) (Fig. 10) that surface changes that occurred after the reaction or during the reaction are less in comparison to those of pure hydrogen exposure.

3.5.2. XRD analysis

The PdeAg films were analysed using XRD before and after hydrogen loading to investigate the effect of hydrogen absorption and desorption mechanism on the metal crystal structure. Fig. 11(a) and (b) show the membrane film for pure hydrogen loading and WGS reaction, respectively. Three major peaks were identified with their corresponding Miller indices for pure PdeAg film in both Fig. 11(A) and (B). Similar patterns for peaks were observed by Cabrera et al. (1994).

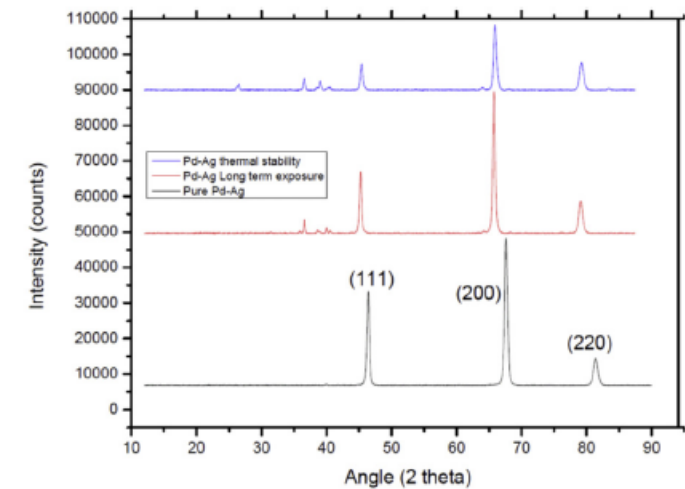

(A)

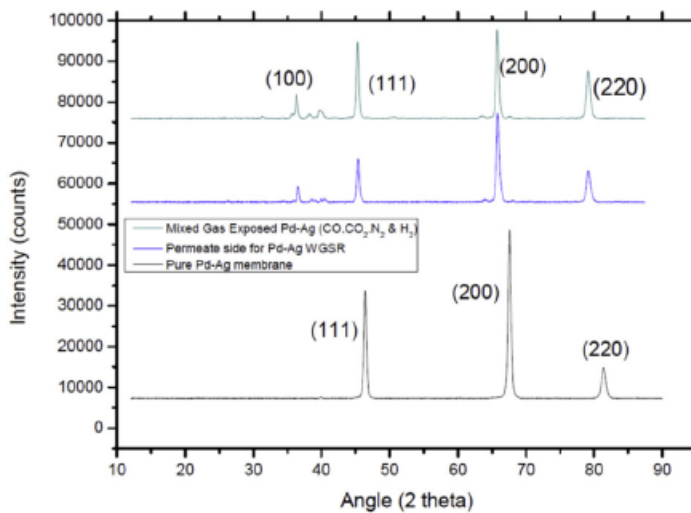

(B)

Fig. 11 – (A) XRD patterns for Pd–Ag film exposed to hydrogen exposed (B) XRD patterns for Pd–Ag used for WGS reaction.

Peak shifting, reduction in peak intensity, broadening of peaks and formation of new peaks were observed for long term hydrogen exposed membrane film. As outlined by Ungar (Ungar, 2004) peak shifting is due to internal stress, twinning and chemical heterogeneities. Therefore, the shifting of peaks was an indication of internal stress caused by the diffusion of hydrogen atoms through the membrane. The diffusion of hydrogen through Pd-based materials has a potential of causing crystal distortion in the material structure. A study by Ungar (Ungar, 2004) outlined the physical meaning of the five basic parameters for XRD peak which are Peak position, peak shape, maximum intensity, symmetry and full width. From Fig. 11(A), the XRD patterns for the mixed gas film and the permeate side of the membrane showed peak shifting and intensity reduction. The instant exposure to hydrogen and diffusion of hydrogen through the metal causes the lattice structure to expand from 3.804 to 3.984 Å during the membrane stability test under hydrogen exposure. The lattice

expansion was also reported by [Cabrera et al. \(1994\)](#) for hydrogen loaded material. An expansion of lattice indicates crystal inhomogeneity which will affect the stability of the membrane. [Table 1](#) shows the lattice parameters for PdeAg membrane film under different process conditions in this work together with literature values for pure Pd. It can be seen that the lattice size of the crystal before and after hydrogen exposure was different. There was lattice expansion after hydrogen exposure of the PdeAg membrane. The occurrence of lattice expansion is accompanied by a crystalline phase change. A prior study [Johansson et al. \(2010\)](#) indicated that the lattice constant for Pd increases by about 3.5% after continuous exposure to hydrogen, which results in the formation of the b-phase. This in turn induces tensile strain in the lattice and causes the membrane to be brittle.

4. Conclusions

The PdeAg membrane reactor diffused hydrogen through the membrane. The diffusion of hydrogen atoms from surface into the bulk membrane and surface contamination was found to be the rate limiting step for hydrogen permeability. The membrane showed good thermal stability at 320 °C for 170 h, but failed at 180 h. The membrane failed earlier at 430 °C (after 150 h) with cracks being formed due to hydrogen diffusion through the membrane. From SEM images, it was seen that cracks were formed on the surface of the membrane film after hydrogen exposure. Micro surface defects were observed due to hydrogen adsorption and desorption. The XRD data showed lattice expansion. Therefore, it can be suggested that the phase transition a- to b-phase caused lattice expansion which may have resulted in the membrane failure. For the WGS reaction, the membrane reactor successfully achieved 84% hydrogen recovery and 88% carbon monoxide conversion in the presence of iron oxide catalyst. High purity hydrogen was produced before the membrane failed. Membrane failure was indicated by the passage of non-permeating gas (N₂).

5. Recommendations

In order to better establish the utility of PdeAg membrane and to develop a more understanding of the science, the following recommendations are made for future work. The membrane tested for extended period of time under different temperatures suffered surfaced morphological changes; the cause of such problem should be investigated further. The concept of hydride formation through the process of hydrogen diffusion process should be further studied by both computational chemistry and experimental methods to develop a better understanding of a brittle phase change of the material.

Acknowledgements

The financial support from the South African Department of Science and Technology (DST) towards HySA Infrastructure KP4 (grant no: HTC004X) is gratefully acknowledged.

References

- Abdollahi, M., Yu, J., Liu, P.K.T., Ciora, R., Sahimi, M., Tsotsis, T.T., 2012. Ultra-pure hydrogen production from reformat mixtures using a palladium membrane reactor system. *J. Membr. Sci.* 390-391 (0), 32-42. <http://dx.doi.org/10.1016/j.memsci.2011.10.053>.
- Augustine, A.S., Ma, Y.H., Kazantzis, N.K., 2011. High pressure palladium membrane reactor for the high temperature water-gas shift reaction. *Int. J. Hydrogen Energy* 36 (9), 5350-5360. <http://dx.doi.org/10.1016/j.ijhydene.2011.01.172>.
- Augustine, A.S., Mardilovich, I.P., Kazantzis, N.K., Hua Ma, Y., 2012. Durability of PSS-supported pd-membranes under mixed gas and wateregas shift conditions. *J. Membr. Sci.* 415-416 (0), 213-220. <http://dx.doi.org/10.1016/j.memsci.2012.05.001>.
- Basile, A., Drioli, E., Santell, F., Violante, V., Capannelli, G., Vitulli, G., 1996. A study on catalytic membrane reactors for water gas shift reaction. *Gas Sep. Purif.* 10 (1), 53-61. [http://dx.doi.org/10.1016/0950-4214\(95\)00023-2](http://dx.doi.org/10.1016/0950-4214(95)00023-2).
- Cabrera, A., Morales-Leal, E., Hasen, J., Schuller, I.K., 1994. Changes in crystallographic orientation of thin foils of palladium and palladium alloys after the absorption of hydrogen. *Catal. Lett.* 30 (1-4), 11-23.
- Caravella, A., Scura, F., Barbieri, G., Drioli, E., 2010. Sieverts law empirical exponent for pd-based membranes: critical analysis in pure H₂ permeation. *J. Phys. Chem. B* 114 (18), 6033-6047.
- Chein, R., Chen, Y., Chung, J.N., 2013. Parametric study of membrane reactors for hydrogen production via high temperature water gas shift reaction. *Int. J. Hydrogen Energy* 38 (5), 2292-2305. <http://dx.doi.org/10.1016/j.ijhydene.2012.11.122>.
- Chotirach, M., Tantayanon, S., Tungasmita, S., Kriausakul, K., 2012. Zr-based intermetallic diffusion barriers for stainless steel supported palladium membranes. *J. Membr. Sci.* 405, 92-103.
- Cooney, D.A., Way, J.D., Wolden, C.A., 2014. A comparison of the performance and stability of Pd/BCC metal composite membranes for hydrogen purification. *Int. J. Hydrogen Energy* 39 (33), 19009-19017.
- Criscuoli, A., Basile, A., Drioli, E., 2000. An analysis of the performance of membrane reactors for the wateregas shift reaction using gas feed mixtures. *Catal. Today* 56 (1-3), 53-64. [http://dx.doi.org/10.1016/S0920-5861\(99\)00262-X](http://dx.doi.org/10.1016/S0920-5861(99)00262-X).
- Diogo Manuel Pereira Mendes, Use of Pd-Ag membrane reactors in the water-gas shift reaction for producing ultra-pure hydrogen, 2010.
- Edlund, D.J., McCarthy, J., 1995. The relationship between intermetallic diffusion and flux decline in composite-metal membranes: implications for achieving long membrane lifetime. *J. Membr. Sci.* 107 (1), 147-153.
- Hara, S., Caravella, A., Ishitsuka, M., Suda, H., Mukaida, M., Haraya, K., Shimano, E., Tsuji, T., 2012. Hydrogen diffusion coefficient and mobility in palladium as a function of equilibrium pressure evaluated by permeation measurement. *J. Membr. Sci.* 421-422 (0), 355-360. <http://dx.doi.org/10.1016/j.memsci.2012.08.002>.
- Hou, K., Hughes, R., 2002. The effect of external mass transfer, competitive adsorption and coking on hydrogen permeation through thin Pd/Ag membranes. *J. Membr. Sci.* 206 (1-2), 119-130. [http://dx.doi.org/10.1016/S0376-7388\(01\)00770-0](http://dx.doi.org/10.1016/S0376-7388(01)00770-0).

- Hwang, K., Lee, S., Ryi, S., Kim, D., Kim, T., Park, J., 2013. Watergas shift reaction in a plate-type pd-membrane reactor over a nickel metal catalyst. *Fuel Process Technol.* 106 (0), 133-140. <http://dx.doi.org/10.1016/j.fuproc.2012.07.013>.
- Isaeva, L., Bazhanov, D., Isaev, E., Eremeev, S., Kulkova, S., Abrikosov, I., 2011. Dynamic stability of palladium hydride: an ab initio study. *Int. J. Hydrogen Energy* 36 (1), 1254-1258.
- Johansson, M., Skulason, E., Nielsen, G., Murphy, S., Nielsen, R.M., Chorkendorff, I., 2010. Hydrogen adsorption on palladium and palladium hydride at 1 bar. *Surf. Sci.* 604 (7), 718-729.
- Liguori, S., Iulianelli, A., Dalena, F., Pinacci, P., Drago, F., Broglia, M., Huang, Y., Basile, A., 2014. Performance and longterm stability of Pd/PSS and Pd/Al₂O₃ membranes for hydrogen separation. *Membranes* 4 (1), 143-162.
- Lin, Y., Rei, M., 2001. Study on the hydrogen production from methanol steam reforming in supported palladium membrane reactor. *Catal. Today* 67 (1), 77-84.
- Ma, Y.H., Akis, B.C., Ayturk, M.E., Guazzone, F., Engwall, E.E., Mardilovich, I.P., 2004. Characterization of intermetallic diffusion barrier and alloy formation for Pd/Cu and Pd/Ag porous stainless steel composite membranes. *Ind. Eng. Chem. Res.* 43 (12), 2936-2945.
- Maleka, E.M., Mashimbye, L., Goyns, P., 2010. Energy information management, process design and publications south African energy synopsis 2010. The Department of Energy of the Republic of South Africa, Pretoria, South Africa Tech. Rep. ISBN: 978-1-920435-4.
- Mardilovich, P.P., She, Y., Ma, Y.H., Rei, M., 1998. Defect-free palladium membranes on porous stainless-steel support. *American Institute of Chemical Engineers AIChE J.* 44 (2), 310.
- Mendes, D., Chibante, V., Zheng, J., Tosti, S., Borgognoni, F., Mendes, A., Madeira, L.M., 2010. Enhancing the production of hydrogen via watergas shift reaction using pd-based membrane reactors. *Int. J. Hydrogen Energy* 35 (22), 12596-12608. <http://dx.doi.org/10.1016/j.ijhydene.2010.07.159>.
- Morreale, B.D., Ciocco, M.V., Enick, R.M., Morsi, B.I., Howard, B.H., Cugini, A.V., Rothenberger, K.S., 2003. The permeability of hydrogen in bulk palladium at elevated temperatures and pressures. *J. Membr. Sci.* 212 (1), 87-97.
- Nakamura, J., Campbell, J.M., Campbell, C.T., 1990. Kinetics and mechanism of the water gas shift reaction catalysed by the clean and cs-promoted cu (110) surface: a comparison with cu (111). *J. Chem. Soc. Faraday Trans.* 86 (15), 2725-2734.
- Okazaki, J., Tanaka, D.A.P., Tanco, M.A.L., Wakui, Y., Mizukami, F., Suzuki, T.M., 2006. Hydrogen permeability study of the thin PdeAg alloy membranes in the temperature range across the aeb phase transition. *J. Membr. Sci.* 282 (1), 370-374.
- Okazaki, J., Ikeda, T., Tanaka, D.A.P., Sato, K., Suzuki, T.M., Mizukami, F., 2011. An investigation of thermal stability of thin palladiumsilver alloy membranes for high temperature hydrogen separation. *J. Membr. Sci.* 366 (1-2), 212-219. <http://dx.doi.org/10.1016/j.memsci.2010.10.011>.
- Peters, T., Tucho, W., Ramachandran, A., Stange, M., Walmsley, J., Holmestad, R., Borg, A., Bredesen, R., 2009. Thin Pde_{23%} Ag/ stainless steel composite membranes: long-

- term stability, lifetime estimation and post-process characterisation. *J. Membr. Sci.* 326 (2), 572-581.
- Suleiman, M., Jisrawi, N., Dankert, O., Reetz, M., B€ahtz, C., Kirchheim, R., Pundt, A., 2003. Phase transition and lattice expansion during hydrogen loading of nanometer sized palladium clusters. *J. Alloys Compd.* 356, 644-648.
- Thoen, P.M., Roa, F., Way, J.D., 2006. High flux palladium-copper composite membranes for hydrogen separations. *Desalination* 193 (1), 224-229.
- Tosti, S., 2010. Overview of Pd-based membranes for producing pure hydrogen and state of art at ENEA laboratories. *Int. J. Hydrogen Energy* 35 (22), 12650-12659. <http://dx.doi.org/10.1016/j.ijhydene.2010.07.116>.
- Tosti, S., Basile, A., Bettinali, L., Borgognoni, F., Chiaravalloti, F., Gallucci, F., 2006. Long-term tests of PdAg thin wall permeator tube. *J. Membr. Sci.* 284 (1), 393-397.
- Uemiya, S., Matsuda, T., Kikuchi, E., 1991. Hydrogen permeable palladium-silver alloy membrane supported on porous ceramics. *J. Membr. Sci.* 56 (3), 315-325. [http://dx.doi.org/10.1016/S0376-7388\(00\)83041-0](http://dx.doi.org/10.1016/S0376-7388(00)83041-0).
- Unemoto, A., Kaimai, A., Sato, K., Otake, T., Yashiro, K., Mizusaki, J., Kawada, T., Tsuneki, T., Shirasaki, Y., Yasuda, I., 2007. The effect of co-existing gases from the process of steam reforming reaction on hydrogen permeability of palladium alloy membrane at high temperatures. *Int. J. Hydrogen Energy* 32 (14), 2881-2887.
- Ungar, T., 2004. Microstructural parameters from X-ray diffraction peak broadening. *Scr. Mater.* 51 (8), 777-781.